

# SMHF Single and Dual DC-DC Converters

## 16-45 VOLT INPUT – 15 WATT

### FEATURES

- Radiation tolerant space dc-dc converter  
Single event effects (SEE) LET performance to 86 MeV cm<sup>2</sup>/mg  
Total ionizing dose (TID) guaranteed per MIL-STD-883 method 1019, radiation hardness assurance (RHA)  
P = 30 krad(Si), L = 50 krad(Si), R = 100 krad(Si)
- Operating temperature -55°C to +125°C
- Qualified to MIL-PRF-38534 Class H and K
- Input voltage range 16 to 45 V
- Transient protection 50 V for 50 ms
- Fully isolated
- Fixed high frequency switching
- Inhibit function
- Synchronization input
- Indefinite short circuit protection
- Undervoltage lockout

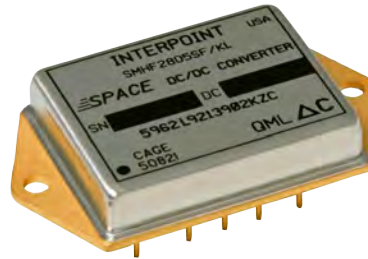

MODELS	
OUTPUT VOLTAGE (V)	
SINGLE	DUAL
3.3	±5
5	±12
5.2	±15
12	
15	

### DESCRIPTION

The Interpoint® SMHF Series™ of 28 V dc-dc converters offers a wide input voltage range of 16 to 45 volts and up to 15 watts of output power. The units are capable of withstanding transients up to 50 volts for up to 50 ms.

### SCREENING

SMHF converters offer screening to Class H or K and radiation hardness assurance (RHA) levels P - 30 krad(Si), L - 50 krad(Si) or R - 100 krad(Si). See Table 10 on page 15 for more information.

### CONVERTER DESIGN

The SMHF converters are switching regulators that use a quasi-square wave, single-ended forward converter design with a constant switching frequency of 550 kHz typical. Isolation between input and output circuits is provided with a transformer in the forward path and a temperature compensated opto-coupler in the feedback control loop. The opto-coupler is radiation tolerant and is especially selected for space applications.

Dual output models maintain cross regulation with tightly coupled output magnetics. Up to 70% of the total output power is available from either output, providing the opposite output is simultaneously carrying 30% of the total output power. Predictable current limit is accomplished by directly monitoring the output load current and providing a constant current output above the overload point.

The SMHF converter's feed-forward compensation system provides excellent dynamic response and noise rejection. Audio rejection is typically 50 dB. Typical output voltage response for a 50% to 100% step load transient is as low as 1.8% with a 150  $\mu$ s recovery time, typical. See Table 5 on page 5 for more information.

SMHF converters provide an inhibit terminal that can be used to disable internal switching, resulting in no output and very low quiescent input current. The converter is inhibited when the inhibit pin is pulled low. The unit is enabled when the pin, which is internally connected to a pull-up resistor, is left unconnected or is connected to an open-collector gate. See Table 5 on page 5 for more information.

The SMHF Series' synchronization feature allows the user to match the switching frequency of the converter to the frequency of the system clock. This allows the user to adjust the nominal 550 kHz operating frequency to any frequency within the range of 500 kHz to 600 kHz by applying a compatible input of the desired frequency to pin 5.

SMHF Series converters provide short circuit protection by restricting the output current to approximately 140% of the full load output current. The output current is sensed in the secondary stage to provide highly predictable and accurate current limiting, and to eliminate foldback characteristics.

Undervoltage lockout prevents the units from operating below approximately 14 volts input to keep system current levels smooth, especially during initialization or re-start operations.

# SMHF Single and Dual DC-DC Converters

16-45 VOLT INPUT – 15 WATT

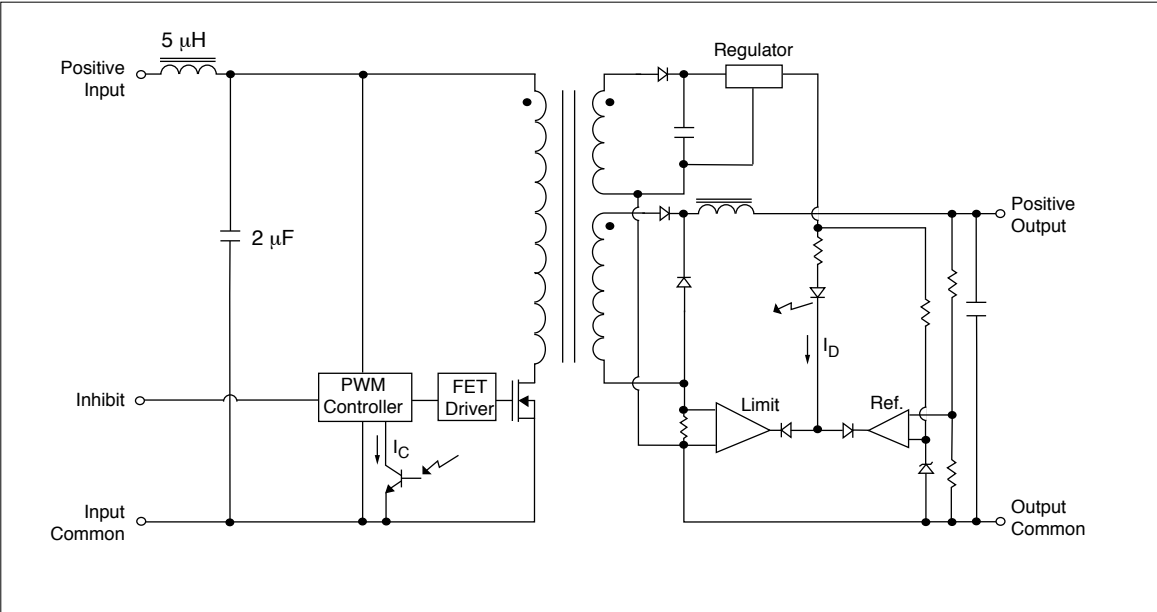

FIGURE 1: SMHF SINGLE OUTPUT, BLOCK DIAGRAM

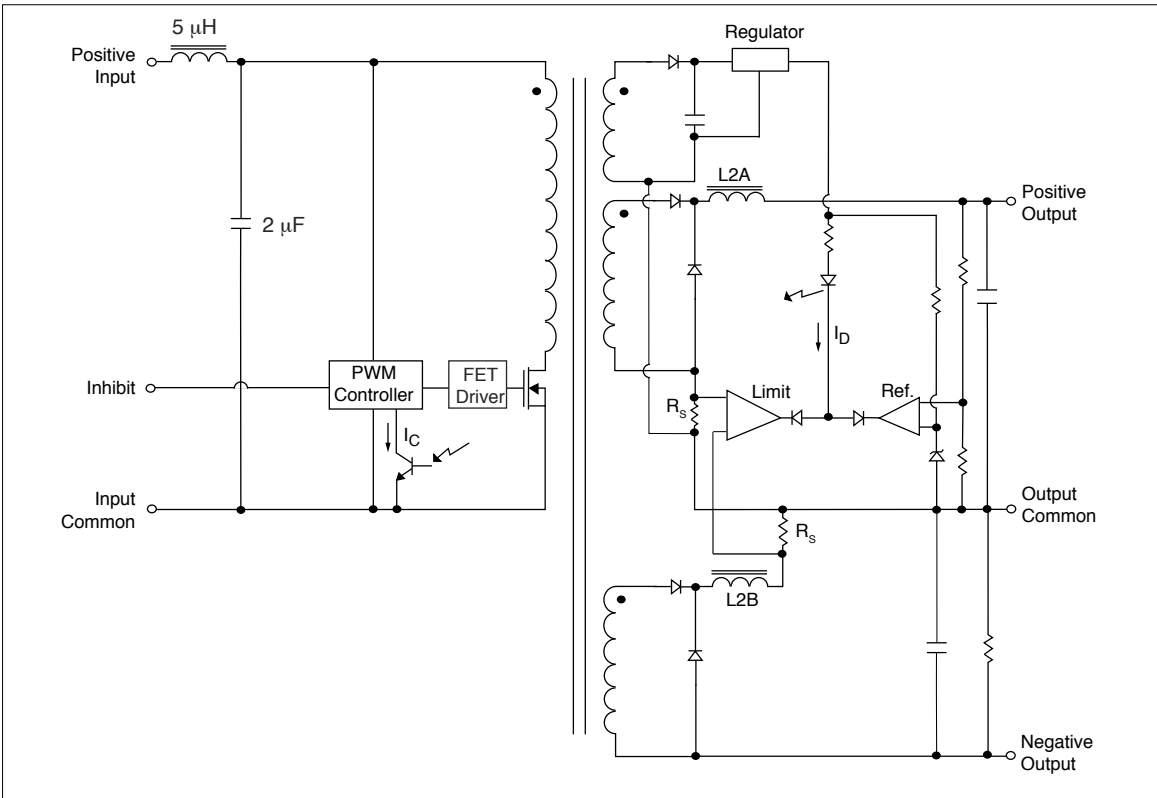

FIGURE 2: SMHF DUAL OUTPUT, BLOCK DIAGRAM

# SMHF Single and Dual DC-DC Converters

## 16-45 VOLT INPUT – 15 WATT

PIN OUT		
Pin	Single Output	Dual Output
1	Inhibit	Inhibit
2	No connection	Positive Output
3	Output Common	Output Common
4	Positive Output	Negative Output
5	Sync	Sync
6	Case Ground	Case Ground
7	Input Common	Input Common
8	Positive Input	Positive Input

TABLE 1: PIN OUT

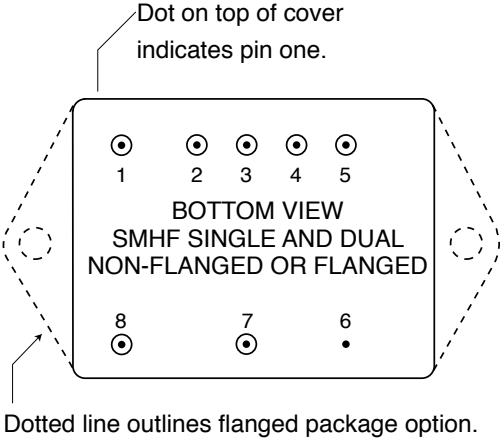

See Figure 27 on page 12 and Figure 28 on page 13 for dimensions.

FIGURE 3: PIN OUT

PINS NOT IN USE	
Inhibit (pin 1)	Leave unconnected
Sync (pin 5)	Connect to Input Common (pin 7)

TABLE 2: PINS NOT IN USE

# SMHF Single and Dual DC-DC Converters

## 16-45 VOLT INPUT – 15 WATT

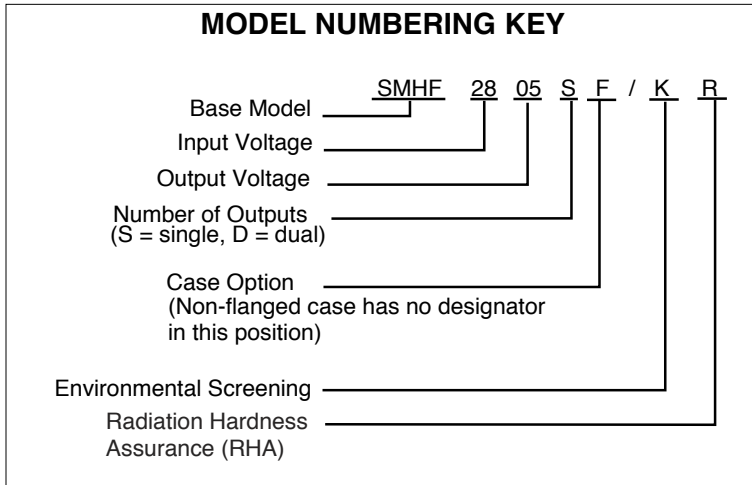

FIGURE 4: MODEL NUMBERING KEY

SMD NUMBERS	
STANDARD MICROCIRCUIT DRAWING (SMD)	SMHF SIMILAR PART
5962R0251002KXC	SMHF283R3S/KR
5962R9213902KXC	SMHF2805S/KR
5962R9166402KXC	SMHF2812S/KR
5962R9160102KXC	SMHF2815S/KR
5962R9555902KXC	SMHF2805D/KR
5962R9214402KXC	SMHF2812D/KR
5962R9161402KXC	SMHF2815D/KR

To indicate the flanged case option change the "X" to "Z" in the SMD number. The SMD number shown is for Class K screening, non-flanged, and radiation hardness assurance (RHA) level R. See the SMD for the numbers for other screening and radiation levels. For exact specifications for an SMD product, refer to the SMD drawing. SMDs can be downloaded from <http://www.landandmaritime.dla.mil/programs/smcr/>

TABLE 3: SMD NUMBER CROSS REFERENCE

MODEL NUMBER OPTIONS <sup>1</sup>						
TO DETERMINE THE MODEL NUMBER ENTER ONE OPTION FROM EACH CATEGORY IN THE FORM BELOW.						
CATEGORY	Base Model and Input Voltage	Output Voltage <sup>2</sup>	Number of Outputs <sup>3</sup>	Case Option <sup>4</sup>	Screening <sup>5</sup>	RHA <sup>6</sup>
OPTIONS	SMHF28	3R3, 05, 5R2, 12, 15	S	(non-flanged, leave blank)	O	O
		05, 12, 15	D	F (flanged)	H K	P L R
FILL IN FOR MODEL #	SMHF28	_____	_____	_____ / _____	_____	_____

Notes

- See Figure 4 above for an example of a model number.
- Output Voltage: An R indicates a decimal point. 3R3 is 3.3 volts out. The values of 3.3 and 5.2 are only available in single output models.
- Number of Outputs: S is a single output and D is a dual output
- Case Options: For the standard case (Figure 27 on page 12) leave the Case Option blank. For the flanged case option (Figure 28 on page 13), insert the letter F in the Case Option position.
- Screening: A screening level of O is a space prototype and is only available with RHA O. See Table 9 on page 14 and Table 10 on page 15 for more information.
- RHA: Interpoint model numbers use an "O" in the RHA designator position to indicate the "-" (dash) radiation hardness assurance level of MIL-PRF-38534, which is defined as "no RHA." RHA O is only available with screening level O. See Table 10 on page 15 for more information.

TABLE 4: MODEL NUMBER OPTIONS

# SMHF Single and Dual DC-DC Converters

## 16-45 VOLT INPUT – 15 WATT

TABLE 5: OPERATING CONDITIONS - ALL MODELS, 25°C CASE, 28 VIN, UNLESS OTHERWISE SPECIFIED

SMHF SERIES		ALL MODELS			UNITS
PARAMETER	CONDITIONS	MIN	TYP	MAX	
LEAD SOLDERING TEMPERATURE <sup>1</sup>	10 SECONDS MAX.	–	–	300	°C
STORAGE TEMPERATURE <sup>1</sup>		-65	–	+150	°C
CASE OPERATING TEMPERATURE	FULL POWER	-55	–	+125	°C
	ABSOLUTE <sup>1</sup>	-55	–	+135	
DERATING OUTPUT POWER/CURRENT <sup>1</sup>	LINEARLY	From 100% at 125°C to 0% at 135°C			
ESD RATING <sup>1</sup> MIL-PRF-38534, 3.9.5.8.2	MIL-STD-883 METHOD 3015 CLASS 1C	1000-1999			V
ISOLATION: INPUT TO OUTPUT OR ANY PIN TO CASE EXCEPT CASE PIN	@ 500 VDC AT 25°C	100	–	–	Megohms
UNDERVOLTAGE LOCKOUT <sup>1</sup>	V <sub>IN</sub>	–	14	–	V
INPUT TO OUTPUT CAPACITANCE <sup>1</sup>		–	60	–	pF
CURRENT LIMIT <sup>1, 2</sup>	% OF FULL LOAD	–	140	–	%
AUDIO REJECTION <sup>1</sup>		–	50	–	dB
CONVERSION FREQUENCY	FREE RUN -55°C TO +125°C	480	550	620	kHz
SYNCHRONIZATION	INPUT FREQUENCY	500	–	600	kHz
	DUTY CYCLE <sup>1</sup>	40	–	60	%
	ACTIVE LOW	–	–	0.8	V
	ACTIVE HIGH <sup>1</sup>	4.5	–	5.0	
	REFERENCED TO	INPUT COMMON			
	IF NOT USED	CONNECT TO INPUT COMMON			
INHIBIT ACTIVE LOW (OUTPUT DISABLED) Do not apply a voltage to the inhibit pin	INHIBIT PIN PULLED LOW	–	–	0.8	V
	INHIBIT PIN SOURCE CURRENT <sup>1</sup>	–	–	5	mA
	REFERENCED TO	INPUT COMMON			
INHIBIT ACTIVE HIGH (OUTPUT ENABLED) Do not apply a voltage to the inhibit pin	INHIBIT PIN CONDITION	OPEN COLLECTOR OR UNCONNECTED			
	OPEN INHIBIT PIN VOLTAGE <sup>1</sup>	7.5	–	12	V

*For mean time between failures (MTBF) contact Applications Engineering  
powerapps@crane-eg.com +1 425-882-3100 option 7*

## Notes

1. Guaranteed by characterization test and/or analysis. Not a production test.
2. Dual outputs: The over-current limit will trigger when the sum of the currents from both outputs reaches 140% (typical value) of the maximum rated "total" current of both outputs.

# SMHF Single and Dual DC-DC Converters

## 16-45 VOLT INPUT – 15 WATT

TABLE 6: ELECTRICAL CHARACTERISTICS: -55°C TO +125°C CASE, 28 VIN, 100% LOAD, UNLESS OTHERWISE SPECIFIED.

SINGLE OUTPUT MODELS		SMHF283R3S			SMHF2805S			SMHF285R2S			UNITS
PARAMETER	CONDITIONS	MIN	TYP	MAX	MIN	TYP	MAX	MIN	TYP	MAX	
OUTPUT VOLTAGE		3.20	3.30	3.40	4.85	5.00	5.15	5.05	5.20	5.35	V
OUTPUT CURRENT	$V_{IN} = 16$ to 45 V	—	—	2.4	—	—	2.4	—	—	2.4	A
OUTPUT POWER	$V_{IN} = 16$ to 45 V	0	—	8	0	—	12	0	—	12.5	W
OUTPUT RIPPLE	$T_C = 25^\circ\text{C}$	—	5	30	—	5	30	—	5	30	mV p-p
10 kHz - 2 MHz	$T_C = -55^\circ\text{C}$ TO $+125^\circ\text{C}$	—	5	30	—	5	30	—	5	30	
LINE REGULATION	$V_{IN} = 16$ TO 45 V	—	1	10	—	1	10	—	1	10	mV
LOAD REGULATION	NO LOAD TO FULL	—	20	50	—	20	50	—	20	50	mV
INPUT VOLTAGE	CONTINUOUS	16	28	45	16	28	45	16	28	45	V
NO LOAD TO FULL	TRANSIENT 50 ms <sup>1</sup>	0	—	50	0	—	50	0	—	50	V
INPUT CURRENT	NO LOAD	—	25	50	—	25	40	—	25	40	mA
	INHIBITED	—	6	10	—	6	10	—	6	10	
INPUT RIPPLE CURRENT	10 kHz - 10 MHz	—	—	120	—	—	120	—	—	120	mA p-p
EFFICIENCY	$T_C = 25^\circ\text{C}$	68	71	—	73	76	—	72	78	—	%
	$T_C = -55^\circ\text{C}$ TO $+125^\circ\text{C}$	65	—	—	70	—	—	70	—	—	
LOAD FAULT <sup>2</sup>	POWER DISSIPATION	—	5	8	—	3.5	8	—	3.5	8	W
SHORT CIRCUIT	RECOVERY <sup>1</sup>	—	7.5	30	—	7.5	30	—	7.5	30	ms
STEP LOAD RESPONSE <sup>3, 4</sup>	TRANSIENT	—	150	400	—	150	400	—	150	400	mV pk
50% - 100% - 50%	RECOVERY	—	150	300	—	150	300	—	150	300	
STEP LINE RESPONSE <sup>1, 4, 5</sup>	TRANSIENT	—	550	800	—	550	800	—	—	800	mV pk
16 - 40 - 16 V	RECOVERY	—	200	500	—	200	500	—	—	600	
STEP LINE RESPONSE <sup>1, 4, 5</sup>	TRANSIENT	—	70	—	—	110	—	—	110	—	mV pk
22 - 32 - 22 V	RECOVERY	—	200	—	—	180	—	—	180	—	
STEP LINE RESPONSE <sup>1, 4, 5</sup>	TRANSIENT	—	100	—	—	160	—	—	160	—	mV pk
36 - 45 - 36 V	RECOVERY	—	250	—	—	180	—	—	180	—	
STARTUP <sup>6</sup>	DELAY	—	10	25	—	10	25	—	10	25	ms
	OVERSHOOT <sup>1</sup>	—	15	50	—	15	50	—	15	50	mV pk
CAPACITIVE LOAD	$T_C = 25^\circ\text{C}$	—	—	300	—	—	300	—	—	300	$\mu\text{F}$

### Notes

1. Guaranteed by characterization test and/or analysis. Not a production test.
2. Indefinite short circuit protection not guaranteed above 125°C (case)
3. Step transition time  $>10 \mu\text{s}$ .
4. Recovery time is measured from application of the transient to the point at which  $V_{out}$  is within regulation.

5. Step transition time  $100 \mu\text{s} \pm 20\%$ .
6. Tested on release from inhibit.

# SMHF Single and Dual DC-DC Converters

## 16-45 VOLT INPUT – 15 WATT

TABLE 7: ELECTRICAL CHARACTERISTICS: -55°C TO +125°C CASE, 28 VIN, 100% LOAD, UNLESS OTHERWISE SPECIFIED.

SINGLE OUTPUT MODELS		SMHF2812S			SMHF2815S			UNITS
PARAMETER	CONDITIONS	MIN	TYP	MAX	MIN	TYP	MAX	
OUTPUT VOLTAGE		11.76	12.00	12.24	14.70	15.00	15.30	V
OUTPUT CURRENT	$V_{IN} = 16$ to 45 V	—	—	1.25	—	—	1.00	A
OUTPUT POWER	$V_{IN} = 16$ to 45 V	0	—	15	0	—	15	W
OUTPUT RIPPLE	$T_C = 25^\circ\text{C}$	—	15	40	—	10	40	mV p-p
10 kHz - 2 MHz	$T_C = -55^\circ\text{C}$ TO $+125^\circ\text{C}$	—	15	40	—	10	40	
LINE REGULATION	$V_{IN} = 16$ TO 45 V	—	5	20	—	8	30	mV
LOAD REGULATION	NO LOAD TO FULL	—	20	50	—	20	50	mV
INPUT VOLTAGE	CONTINUOUS	16	28	45	16	28	45	V
NO LOAD TO FULL	TRANSIENT 50 ms <sup>1</sup>	0	—	50	0	—	50	V
INPUT CURRENT	NO LOAD	—	25	55	—	25	62	mA
	INHIBITED	—	5	10	—	5	10	
INPUT RIPPLE CURRENT	10 kHz - 10 MHz	—	—	120	—	—	120	mA p-p
EFFICIENCY	$T_C = 25^\circ\text{C}$	76	79	—	78	78	—	%
	$T_C = -55^\circ\text{C}$ TO $+125^\circ\text{C}$	72	—	—	74	—	—	
LOAD FAULT <sup>2</sup>	POWER DISSIPATION	—	3.5	8	—	3.5	8	W
SHORT CIRCUIT	RECOVERY <sup>1</sup>	—	7.5	30	—	7.5	30	ms
STEP LOAD RESPONSE <sup>3, 4</sup>	TRANSIENT	—	150	500	—	200	500	mV pk
50% - 100% - 50%	RECOVERY	—	50	300	—	50	300	$\mu\text{s}$
STEP LINE RESPONSE <sup>1, 4, 5</sup>	TRANSIENT	—	550	800	—	550	800	mV pk
16 - 40 - 16 V	RECOVERY	—	300	700	—	300	700	$\mu\text{s}$
STEP LINE RESPONSE <sup>1, 4, 5</sup>	TRANSIENT	—	250	—	—	250	—	mV pk
22 - 32 - 22 V	RECOVERY	—	210	—	—	210	—	$\mu\text{s}$
STEP LINE RESPONSE <sup>1, 4, 5</sup>	TRANSIENT	—	350	—	—	350	—	mV pk
36 - 45 - 36 V	RECOVERY	—	300	—	—	300	—	$\mu\text{s}$
STARTUP <sup>6</sup>	DELAY	—	10	25	—	10	25	ms
	OVERSHOOT <sup>1</sup>	—	25	50	—	25	50	mV pk
CAPACITIVE LOAD	$T_C = 25^\circ\text{C}$	—	—	100	—	—	100	$\mu\text{F}$

## Notes

1. Guaranteed by characterization test and/or analysis. Not a production test.
2. Indefinite short circuit protection not guaranteed above 125°C (case)
3. Step transition time >10  $\mu\text{s}$ .
4. Recovery time is measured from application of the transient to the point at which  $V_{out}$  is within regulation.

5. Step transition time 100  $\mu\text{s}$   $\pm 20\%$ .
6. Tested on release from inhibit.

# SMHF Single and Dual DC-DC Converters

## 16-45 VOLT INPUT – 15 WATT

TABLE 8: ELECTRICAL CHARACTERISTICS: -55°C TO +125°C CASE, 28 VIN, 100% LOAD, UNLESS OTHERWISE SPECIFIED.

DUAL OUTPUT MODELS		SMHF2805D			SMHF2812D			SMHF2815D			UNITS
PARAMETER	CONDITIONS	MIN	TYP	MAX	MIN	TYP	MAX	MIN	TYP	MAX	
OUTPUT VOLTAGE	+V <sub>OUT</sub>	4.85	5.00	5.15	11.76	12.00	12.24	14.70	15.00	15.30	V
	-V <sub>OUT</sub>	4.82	5.00	5.18	11.70	12.00	12.30	14.63	15.00	15.38	
OUTPUT CURRENT <sup>2</sup> V <sub>IN</sub> = 16 to 45 V	EITHER OUTPUT	—	±1.2	1.68	—	±0.625	0.875	—	±0.5	0.7	A
	TOTAL	—	—	2.4	—	—	1.25	—	—	1.0	
OUTPUT POWER <sup>2</sup> V <sub>IN</sub> = 16 to 45 V	EITHER OUTPUT	—	±6	8.4	—	—	10.5	—	—	10.5	W
	TOTAL	—	—	12	—	—	15	—	—	15	
OUTPUT RIPPLE ± V <sub>OUT</sub> , 10 kHz - 2 MHz	T <sub>C</sub> = 25°C	—	30	95	—	30	95	—	30	95	mV p-p
	T <sub>C</sub> = -55°C TO +125°C	—	30	95	—	30	95	—	30	95	
LINE REGULATION <sup>3</sup> V <sub>IN</sub> = 16 TO 45 V	+V <sub>OUT</sub>	—	2	10	—	2	18	—	2	18	mV
	-V <sub>OUT</sub>	—	10	100	—	10	100	—	10	100	
LOAD REGULATION <sup>3</sup> NO LOAD TO FULL	+V <sub>OUT</sub>	—	5	25	—	5	25	—	5	25	mV
	-V <sub>OUT</sub>	—	80	150	—	60	150	—	40	150	
CROSS REGULATION <sup>4</sup>	EFFECT ON -V <sub>OUT</sub>	—	6	7.5	—	3	6	—	3	6	%
INPUT VOLTAGE NO LOAD TO FULL	CONTINUOUS	16	28	45	16	28	45	16	28	45	V
	TRANSIENT 50 ms <sup>1</sup>	—	—	50	—	—	50	—	—	50	
INPUT CURRENT	NO LOAD	—	25	50	—	30	50	—	30	50	mA
	INHIBITED	—	6	10	—	6	10	—	6	10	
INPUT RIPPLE CURRENT	10 kHz - 10 MHz	—	60	120	—	55	120	—	55	120	mA p-p
EFFICIENCY	T <sub>C</sub> = 25°C	75	77	—	76	80	—	76	82	—	%
	T <sub>C</sub> = -55°C TO +125°C	72	—	—	74	—	—	74	—	—	
LOAD FAULT <sup>5</sup>	POWER DISSIPATION	—	3	6	—	3	6	—	3	6	W
SHORT CIRCUIT	RECOVERY <sup>1</sup>	—	6	30	—	6	50	—	6	50	ms
STEP LOAD RESPONSE <sup>6, 7, 8</sup> 50% - 100% - 50% Bal Loads	TRANSIENT	—	±200	±500	—	±300	±600	—	±300	±600	mV pk
	RECOVERY	—	90	400	—	90	400	—	90	400	
STEP LINE RESPONSE <sup>1, 6, 9</sup> ± V <sub>OUT</sub> , 16 - 40 - 16 V	TRANSIENT	—	±500	±800	—	±500	±750	—	±550	±750	mV pk
	RECOVERY	—	200	700	—	300	900	—	300	900	
STEP LINE RESPONSE <sup>1, 6, 9</sup> ± V <sub>OUT</sub> , 22 - 32 - 22 V	TRANSIENT	—	±125	—	—	±160	—	—	±160	—	mV pk
	RECOVERY	—	200	—	—	160	—	—	160	—	
STEP LINE RESPONSE <sup>1, 6, 9</sup> ± V <sub>OUT</sub> , 36 - 45 - 36 V	TRANSIENT	—	±200	—	—	±250	—	—	±250	—	mV pk
	RECOVERY	—	160	—	—	200	—	—	200	—	
STARTUP <sup>10</sup>	DELAY	—	12	25	—	10	20	—	10	20	ms
	OVERSHOOT <sup>1</sup>	0	100	500	0	100	500	0	100	500	
CAPACITIVE LOAD <sup>11</sup>	T <sub>C</sub> = 25°C	—	—	47	—	—	10	—	—	10	μF

## Notes

- Guaranteed by characterization test and/or analysis. Not a production test.
- Up to 70% of the total output power is available from either output providing the opposite output is simultaneously carrying 30% of the total output power. Each output must carry a minimum of 30% of the total output power in order to maintain regulation on the negative output.
- Balanced loads.
- Effect on -V<sub>OUT</sub> for the following conditions, percentages are of total power:  
+P<sub>O</sub> = 50%, -P<sub>O</sub> = 10%; +P<sub>O</sub> = 10%, -P<sub>O</sub> = 50%  
+P<sub>O</sub> = 70%, -P<sub>O</sub> = 30%; +P<sub>O</sub> = 30%, -P<sub>O</sub> = 70%  
All conditions are referenced to balanced loads of 50%/50%.
- Indefinite short circuit protection not guaranteed above 125°C (case)
- Recovery time is measured from application of the transient to point at which V<sub>OUT</sub> is within regulation.
- Response of either output with the opposite output held at half of the total output power.
- Step transition time >10 μs.
- Step transition time 100 μs ±20%.
- Tested on release from inhibit.
- Applies to each output.



# SMHF Single and Dual DC-DC Converters

## 16-45 VOLT INPUT – 15 WATT

TYPICAL PERFORMANCE PLOTS: 25°C CASE, 28 V<sub>IN</sub>, 100% LOAD, FREE RUN, UNLESS OTHERWISE SPECIFIED. These are examples for reference only and are not guaranteed specifications.

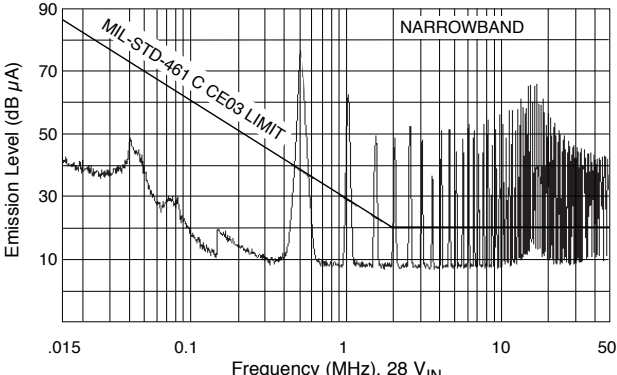

Frequency (MHz), 28 V<sub>IN</sub>  
SMHF2805S, unfiltered,  
Representative of the SMHF Series of DC-DC Converters  
FIGURE 5

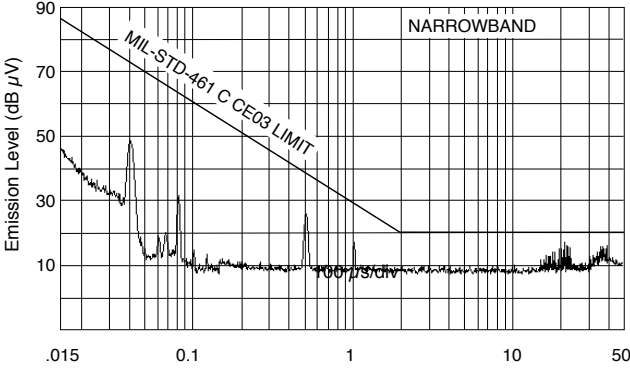

Frequency (MHz), 28 V<sub>IN</sub>  
SMHF2805S with Interpoint SFMC28-461 EMI Filter,  
Representative of the SMHF Series of DC-DC Converters  
FIGURE 6

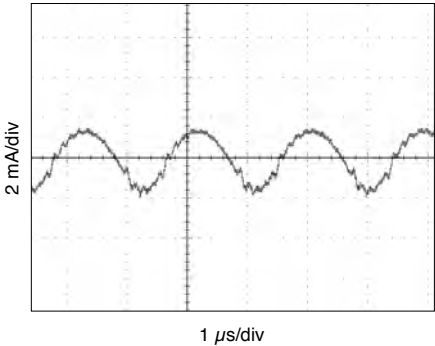

Representative of  
SMHF Series I<sub>IN</sub> Ripple  
FIGURE 7

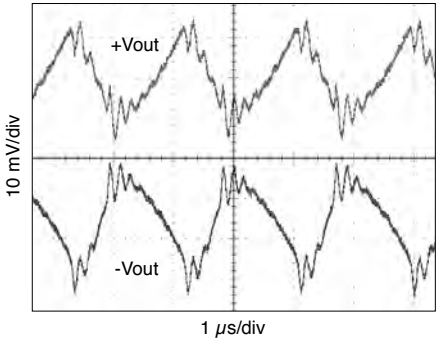

Representative of  
SMHF Series V<sub>OUT</sub> Ripple  
FIGURE 8

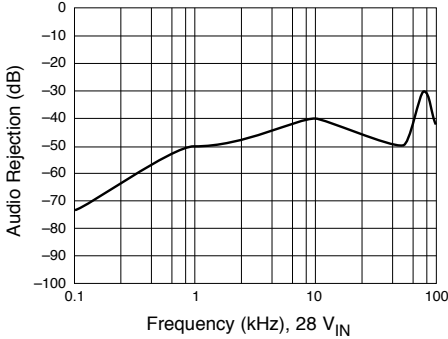

SMHF Series Single Audio Rejection  
FIGURE 9

# SMHF Single and Dual DC-DC Converters

## 16-45 VOLT INPUT – 15 WATT

TYPICAL PERFORMANCE PLOTS: 25°C CASE, 28 V<sub>IN</sub>, 100% LOAD, FREE RUN, UNLESS OTHERWISE SPECIFIED.  
 These are examples for reference only and are not guaranteed specifications.

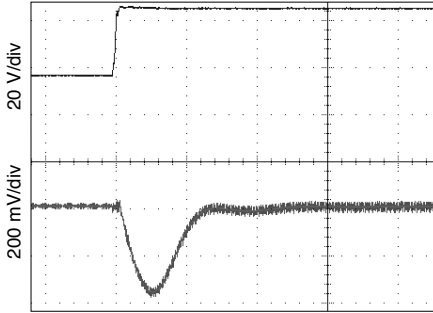

100  $\mu$ s/div  
 V<sub>IN</sub> 16 to 45 V, full resistive load  
 SMHF2805S Representative of  
 Single Output Line Transient

FIGURE 10

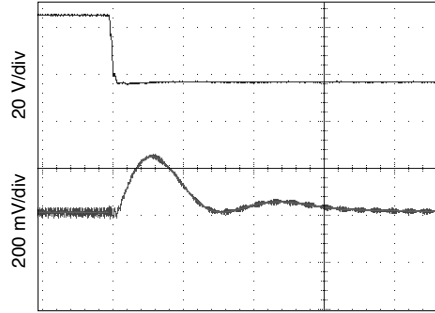

100  $\mu$ s/div  
 V<sub>IN</sub> 45 to 16 V, full resistive load  
 SMHF2805S Representative of  
 Single Output Line Transient

FIGURE 11

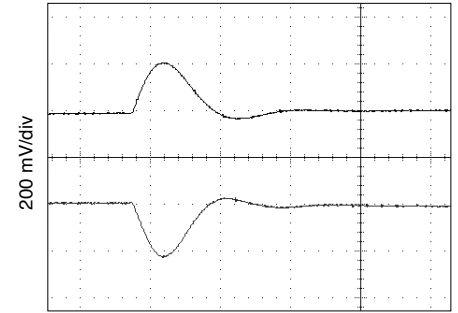

100  $\mu$ s/div  
 50 - 100 - 50% Load  
 SMHF2805S Representative of  
 Single Output Load Transient

FIGURE 12

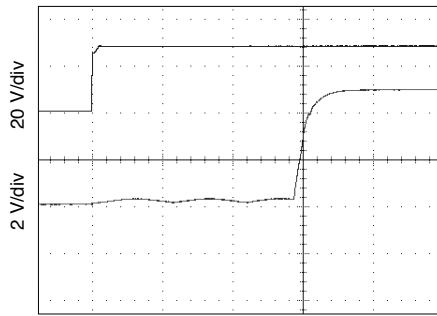

4 ms/div  
 Full resistive load  
 SMHF2805S Representative of  
 Single Output Turn-On Delay

FIGURE 13

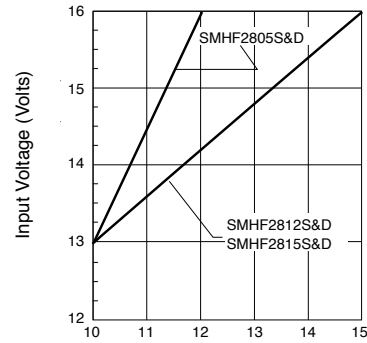

50 mV Drop  
 SMHF2805S Representative of  
 Single Output Low Line Dropout vs. Load

FIGURE 14

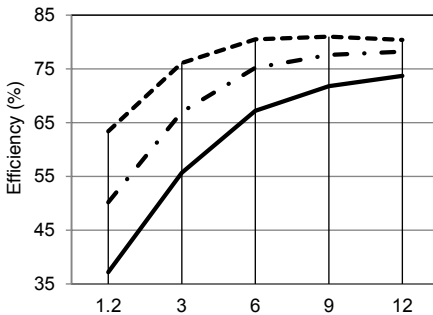

SMHF2805S Efficiency

FIGURE 15

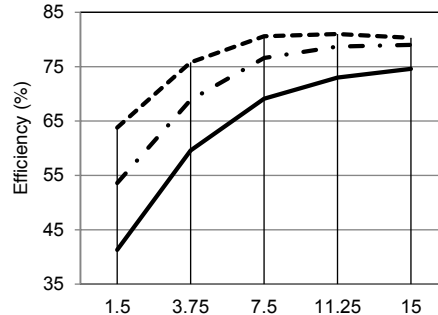

SMHF2812S Efficiency

FIGURE 16

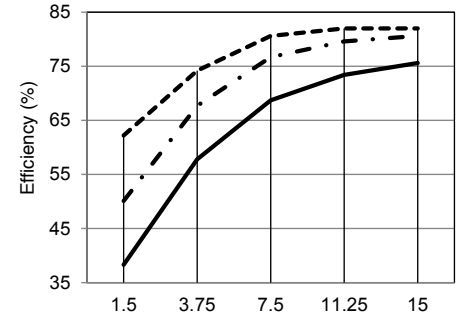

SMHF2815S Efficiency

FIGURE 17

# SMHF Single and Dual DC-DC Converters

## 16-45 VOLT INPUT – 15 WATT

TYPICAL PERFORMANCE PLOTS: 25°C CASE, 28 V<sub>IN</sub>, 100% LOAD, FREE RUN, UNLESS OTHERWISE SPECIFIED.  
 These are examples for reference only and are not guaranteed specifications.

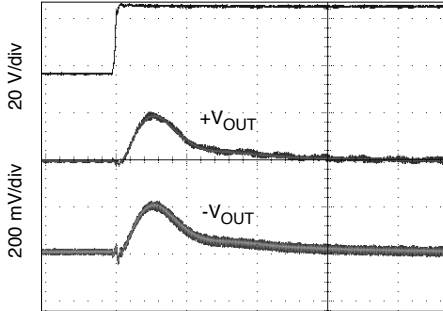

100  $\mu$ s/div  
 V<sub>IN</sub> 16 to 45 V, full resistive load  
 SMHF2815D Representative of  
 Dual Output Line Transient

FIGURE 18

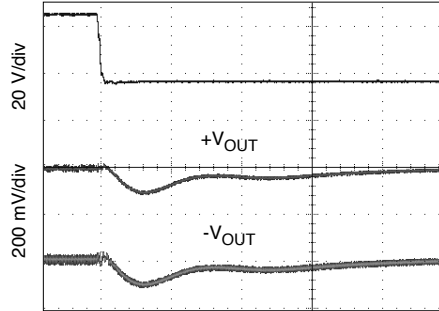

100  $\mu$ s/div  
 V<sub>IN</sub> 16 to 45 V, full resistive load  
 SMHF2815D Representative of  
 Dual Output Line Transient

FIGURE 19

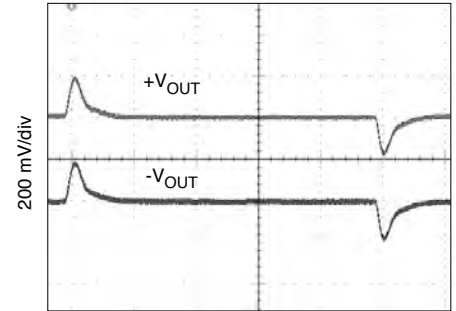

100  $\mu$ s/div  
 50 - 100 - 50% Load  
 SMHF2815D Representative of  
 Dual Output Load Transient

FIGURE 20

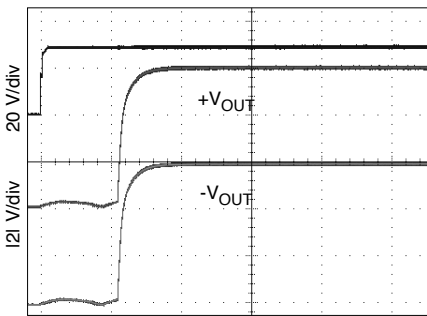

4 ms/div  
 Full resistive load  
 SMHF2815D Representative of  
 Dual Output Turn-On Delay

FIGURE 21

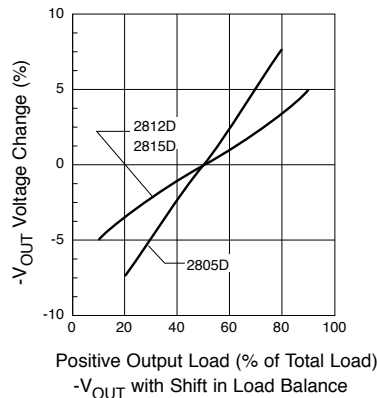

Positive Output Load (% of Total Load)  
 -V<sub>OUT</sub> with Shift in Load Balance

SMHF Dual Cross Regulation

FIGURE 22

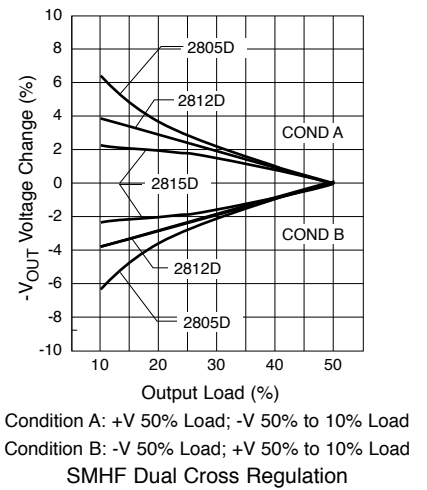

Condition A: +V 50% Load; -V 50% to 10% Load  
 Condition B: -V 50% Load; +V 50% to 10% Load  
 SMHF Dual Cross Regulation

FIGURE 23

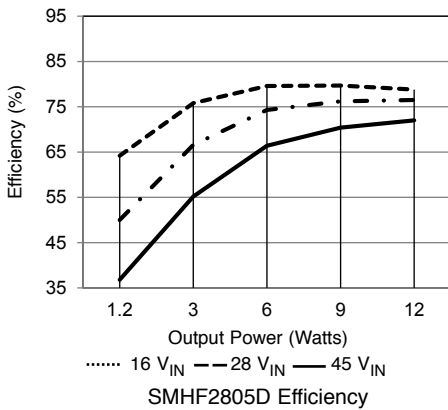

SMHF2805D Efficiency

FIGURE 24

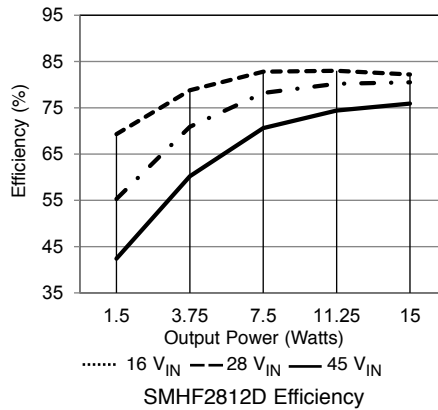

SMHF2812D Efficiency

FIGURE 25

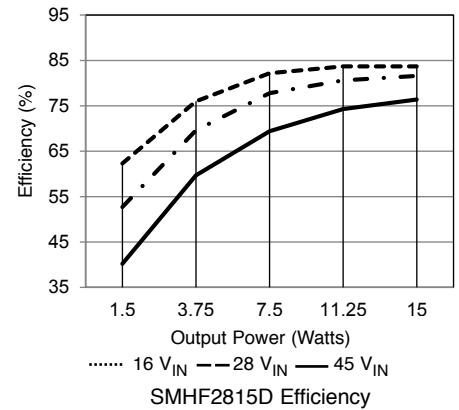

SMHF2815D Efficiency

FIGURE 26

# SMHF Single and Dual DC-DC Converters

## 16-45 VOLT INPUT – 15 WATT

BOTTOM VIEW CASE E1

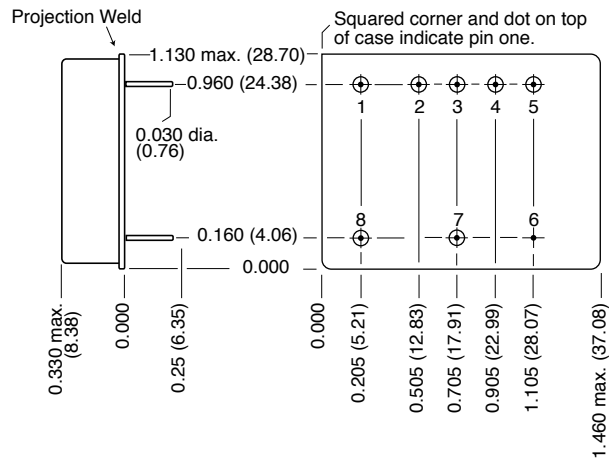

**Weight:** 30 grams maximum

**Case dimensions in inches (mm)**

Tolerance  $\pm 0.005$  (0.13) for three decimal places  
 $\pm 0.01$  (0.3) for two decimal places  
 unless otherwise specified

**CAUTION**

Heat from reflow or wave soldering may damage the device. Solder pins individually with heat application not exceeding 300°C for 10 seconds per pin.

**Materials**

Header Cold Rolled Steel/Nickel/Gold  
 Cover Kovar/Nickel  
 Pins #52 alloy/Gold compression glass seal.  
 Gold plating of 50 - 150 microinches included in pin diameter  
 Seal Hole:  $0.080 \pm 0.002$  (2.03  $\pm 0.05$ )

Please refer to the numerical dimensions for accuracy.

FIGURE 27: CASE E1

# SMHF Single and Dual DC-DC Converters

## 16-45 VOLT INPUT – 15 WATT

### BOTTOM VIEW CASE G1

Flanged cases: Designator "F" required in Case Option position of model number

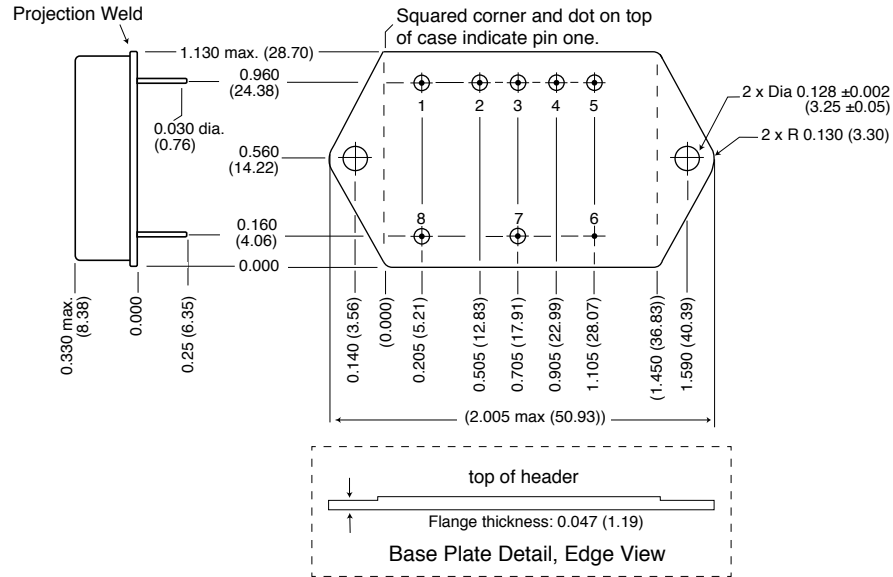

**Weight:** 30 grams maximum

#### Case dimensions in inches (mm)

Tolerance ±0.005 (0.13) for three decimal places  
 ±0.01 (0.3) for two decimal places  
 unless otherwise specified

#### CAUTION

Heat from reflow or wave soldering may damage the device. Solder pins individually with heat application not exceeding 300°C for 10 seconds per pin.

#### Materials

Header Cold Rolled Steel/Nickel/Gold  
 Cover Kovar/Nickel  
 Pins #52 alloy/Gold compression glass seal  
 Gold plating of 50 - 150 microinches included in pin diameter  
 Seal Hole: 0.080 ±0.002 (2.03 ±0.05)

Please refer to the numerical dimensions for accuracy.

FIGURE 28: CASE G1

# SMHF Single and Dual DC-DC Converters

## 16-45 VOLT INPUT – 15 WATT

### DC-DC CONVERTERS PROTOTYPE, CLASS H AND CLASS K, MIL-PRF-38534 ELEMENT EVALUATION

COMPONENT-LEVEL TEST PERFORMED	NON-QML <sup>1</sup>	QML			
	PROTOTYPE	CLASS H		CLASS K	
	/O	/H		/K	
	M/S <sup>2</sup>	M/S <sup>2</sup>	P <sup>3</sup>	M/S <sup>2</sup>	P <sup>3</sup>
Element Electrical	■	■	■	■	■
Visual		■	■	■	■
Internal Visual		■		■	
Temperature Cycling				■	■
Constant Acceleration				■	■
Interim Electrical				■	
Burn-in				■	
Post Burn-in Electrical				■	
Steady State Life				■	
Voltage Conditioning Aging					■
Visual Inspection					■
Final Electrical		■	■	■	■
Wire Bond Evaluation		■	■	■	■
SEM				■	

**Notes**

1. Non-QML products may not meet all of the requirements of MIL-PRF-38534.
2. M/S = Active components (microcircuit and semiconductor die)
3. P = Passive components, Class H and K element evaluation. Not applicable to space prototype ("O") element evaluation.

**Definitions:**

Element Evaluation: Component testing/screening per MIL-STD-883 as determined by MIL-PRF-38534  
SEM: Scanning Electron Microscopy

TABLE 9: ELEMENT EVALUATION—DC-DC CONVERTERS PROTOTYPE, CLASS H AND CLASS K

# SMHF Single and Dual DC-DC Converters

16-45 VOLT INPUT – 15 WATT

## ENVIRONMENTAL SCREENING SPACE DC-DC CONVERTERS PROTOTYPE, CLASS H AND CLASS K, RHA <sup>1</sup> P, L OR R

TEST PERFORMED	NON-QML <sup>2</sup>	QML <sup>3</sup>					
	PROTOTYPE	CLASS H			CLASS K		
	/OO <sup>4</sup>	/HP	/HL	/HR	/KP	/KL	/KR
Non-destruct wire bond pull, Method 2023		■ <sup>5</sup>	■ <sup>5</sup>	■ <sup>5</sup>	■	■	■
Pre-cap Inspection, Method 2017, 2032	■	■	■	■	■	■	■
Temperature Cycle (10 times) (Qual 100 times) Method 1010, Cond. C, -65°C to +150°C, ambient	■	■	■	■	■	■	■
Constant Acceleration Method 2001, 3000 g (Qual 5000 g)	■	■	■	■	■	■	■
PIND, Test Method 2020, Cond. A		■ <sup>5</sup>	■ <sup>5</sup>	■ <sup>5</sup>	■	■	■
Pre burn-in test, Group A, Subgroups 1 and 4	■	■ <sup>5</sup>	■ <sup>5</sup>	■ <sup>5</sup>	■	■	■
Burn-in Method 1015, +125°C case, typical <sup>6</sup>							
96 hours	■						
160 hours		■	■	■			
2 x 160 hours (includes mid-BI test)					■	■	■
Final Electrical Test, MIL-PRF-38534, Group A, Subgroups 1 and 4: +25°C case	■						
Subgroups 1 through 6, -55°C, +25°C, +125°C case		■	■	■	■	■	■
Hermeticity Test, Method 1014							
Gross Leak, Cond. B <sub>2</sub> , Kr-85					■	■	■
Gross Leak, Cond. C <sub>1</sub> , fluorocarbon	■	■	■	■			
Fine Leak, Cond. B <sub>1</sub> , Kr-85					■	■	■
Fine Leak, Cond. A <sub>2</sub> , helium	■	■	■	■			
Radiography, Method 2012					■	■	■
Post Radiography Electrical Test, +25°C case					■ <sup>5</sup>	■ <sup>5</sup>	■ <sup>5</sup>
Final visual inspection, Method 2009	■	■	■	■	■	■	■
RHA P: 30 krad(Si) total dose <sup>1</sup>		■			■		
RHA L: 50 krad(Si) total dose <sup>1</sup>			■			■	
RHA R: 100 krad(Si) total dose <sup>1</sup>				■			■
SEE, LET 86 MeV cm <sup>2</sup> /mg <sup>1</sup>		■	■	■	■	■	■

Test methods are referenced to MIL-STD-883 as determined by MIL-PRF-38534.

- Notes
- Our Redmond facility has a DLA approved RHA plan for Interpoint power products. Our SMD products with RHA "P", "L" or "R" code meet DLA requirements.
  - Non-QML products, O, may not meet all of the requirements of MIL-PRF-38534.
  - All processes are QML qualified and performed by certified operators.
  - "O" in the RHA designator position in Interpoint model numbers indicates DLA RHA "-" defined as no RHA.
  - Not required by DLA but performed to assure product quality.
  - Burn-in temperature designed to bring the case temperature to +125°C minimum. Burn-in is a powered test.

TABLE 10: ENVIRONMENTAL SCREENING AND RHA-DC-DC CONVERTERS PROTOTYPE, CLASS H AND CLASS K, RHA P, L OR R

