

FEATURES

- -55°C to $+125^{\circ}\text{C}$
- 12 to 50 VDC input
- Works through transients of up to 80 V for up to 20 ms.
- Powers DC/DC converters requiring 28 Vin nominal
- Undervoltage lockout
- Inhibit function
- Sync function

LINE CONDITIONING MODULE 28 VOLT INPUT

**LCM-120
120 WATT**



MODEL	
LCM-120	Output 24 to 36 VDC

Size (max.): 1.505 x 3.005 x 0.400 inches
(38.23 x 76.33 x 10.16 mm)
See Section B8, case U1, for dimensions.
Weight: 95 grams max.
Screening: Standard or ES. See Section C2 for screening options, see Section A5 for ordering information.

DESCRIPTION

The LCM-120™ Line Conditioning Module is a non-isolated DC/DC converter used to extend the input voltage range of Interpoint's DC/DC converters. The LCM-120 delivers up to 120 watts of throughput power from a 12 to 50 volt DC source in one of three modes:

1. 12 to 24 volts input – internal boost converter delivers 24 volts
2. 24 to 36 volts input – input is connected directly to output
3. 36 to 50 volts input – internal buck converter delivers 36 volts.

CONVERTER DESIGN

The LCM-120 module is protected by internal current limit circuitry which limits current according to input voltage. This feature also allows safe charging of large external capacitors. Because current is sensed between input common and output common there is normally no external connection made between these pins. (Note: If an external connection between input and output common is desired, the resistance of this external connection must be greater than 1 ohm.) The LCM module will work through up to an 80 volt transient for up to 120 milliseconds while holding the output at 36 VDC.

FEATURES

Features include an under voltage lockout, an inhibit input, a synchronization input and a power fail flag output. Under voltage lockout prevents start-up for inputs less than 12 volts DC and will shut down the converter for an input of less than 10 volts DC. The inhibit input, when connected to input common, disables the internal

converters and opens the output power path while leaving the power fail flag unaffected. Inhibit is normally left open or pulled up with a resistor. The sync input allows synchronization of the LCM-120 module's internal clock to an external pulse source with LSTTL level voltages and a 40% to 60% duty cycle. When unused, the sync should be left unconnected. The power fail flag output is a fully isolated NPN opto-coupler transistor rated to 18 volts DC. It will drive an external LSTTL load low if the LCM-120 module's input voltage drops below 10 volts DC and will remain active until the module output voltage also drops below 10 volts DC.

LOW VIN AND HEAVY LOADS

When the LCM-120 module is operated at 12 volts in and 120 watts output, line loss can become a major concern. The module will output 24 volts at 120 watts. Allowing for efficiency, the input current will be $[(120 \text{ watts} / 0.88) / 12] = 11.36 \text{ A}$. If the resistance in the line from the power source to the LCM-120 is 0.05 ohms, the line loss at 12 volts from the power source will be $(0.05 \cdot 11.36) = 0.57 \text{ volts}$. The LCM-120 module will see 11.43 volts and will not start up.

EXTERNAL CAPACITANCE

Interpoint recommends a minimum output capacitance of 330 μF and a total ESR of at least 0.25 ohms to ensure stability of the LCM-120 module's boost converter. For very low ESR capacitors, an external series resistor (non-inductive) may be used to obtain the minimum total ESR. The maximum recommended capacitance is 1F.

LCM-120 120 WATT

LINE CONDITIONING MODULE

ABSOLUTE MAXIMUM RATINGS	
Input Voltage Range	<ul style="list-style-type: none"> 12 to 50 continuous
Output Power	<ul style="list-style-type: none"> 120 watts
Lead Soldering Temperature (10 sec per lead)	<ul style="list-style-type: none"> 300°C
Storage Temperature Range (Case)	<ul style="list-style-type: none"> -65°C to +150°C

SYNC AND INHIBIT	
Sync (550 to 650 kHz.)	<ul style="list-style-type: none"> Duty cycle 40% to 60% Logic low 0.8V, max Logic high 4.5 V, min Referenced to input common If sync is not used, leave unconnected
Inhibit: TTL Open Collector	<ul style="list-style-type: none"> Logic low (output disabled) Logic low voltage 1.3 V max Referenced to input common Logic high (output enabled)

TYPICAL CHARACTERISTICS	
Output Voltage Temperature Coefficient	<ul style="list-style-type: none"> 0.01%/°C, typical
Isolation: Any pin to case	<ul style="list-style-type: none"> 100 megohm minimum at 500 V
Conversion Frequency	<ul style="list-style-type: none"> Free run mode 600 kHz, typical External sync range 550 to 650 kHz
Inhibit Pin Voltage (unit enabled)	<ul style="list-style-type: none"> 10 V typical

RECOMMENDED OPERATING CONDITIONS	
Input Voltage Range	<ul style="list-style-type: none"> 12 to 50 VDC continuous 80 V for 120 msec transient
Case Operating Temperature (Tc)	<ul style="list-style-type: none"> -55°C to +125°C full power -65°C to +135°C absolute
Derating Output Power/Current	<ul style="list-style-type: none"> Derate linearly from 100% at 125°C to 0% at 135°C

Electrical Characteristics: 25°C Tc, 28 VDC Vin, 100% load, free run, unless otherwise specified.

PARAMETERS	CONDITIONS	INPUT VOLTAGE			UNITS
		AS A CONDITION	MIN	TYP	
OUTPUT VOLTAGE	CONTINUOUS	12 TO 24	23	24	24.5
		24 TO 36	—	V _{IN}	—
		36 TO 50	35	36	37.5
	TRANSIENT 120 ms MAX	50 TO 80	—	36	—
OUTPUT POWER		12 TO 50	—	—	120
OUTPUT RIPPLE	FULL LOAD BW = 10 kHz TO 2 MHz	12 TO 24	—	150	—
		24 TO 36	—	50	—
		36 to 50	—	1500	—
INPUT VOLTAGE	CONTINUOUS		12	28	50
	TRANSIENT 120 ms		—	—	80
INPUT CURRENT	NO LOAD	12	—	125	160
		24	—	50	85
		36	—	20	—
	INHIBITED, PIN 11 = 0 V	12	—	50	—
		24	—	24	—
		36	—	18	—
INPUT RIPPLE	FULL LOAD BW = 10 kHz TO 10 MHz	—	—	150	—
EFFICIENCY	FULL LOAD	12	—	88	—
		24	—	95	—
		36	—	90	—
INHIBIT CURRENT	INHIBITED, PIN 11 = 0 VDC	12 TO 80	—	1	—
POWER FAIL FLAG	V _{OUT} > 10, PIN 6 FLAG CURRENT = 0.4 mA	< 9.5	—	0.4, PIN 9	—
POWER FAIL THRESHOLD V	V _{IN} FALLING		—	9.5	10
UNDERVOLTAGE LOCKOUT	V _{IN} RISING		—	11.5	12
OUTPUT CAPACITOR	ESR > 0.25 OHMS		330	—	1,000,000

LINE CONDITIONING MODULE

LCM-120
120 WATT

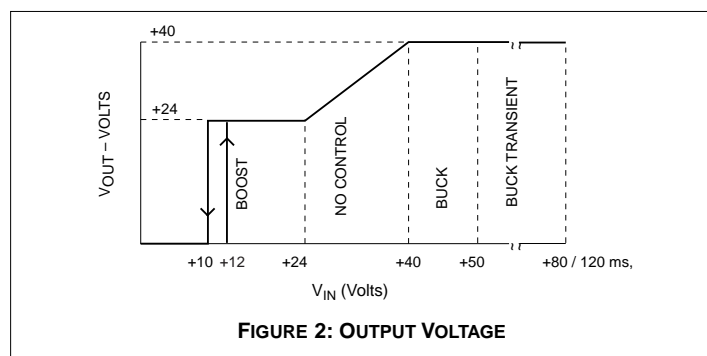
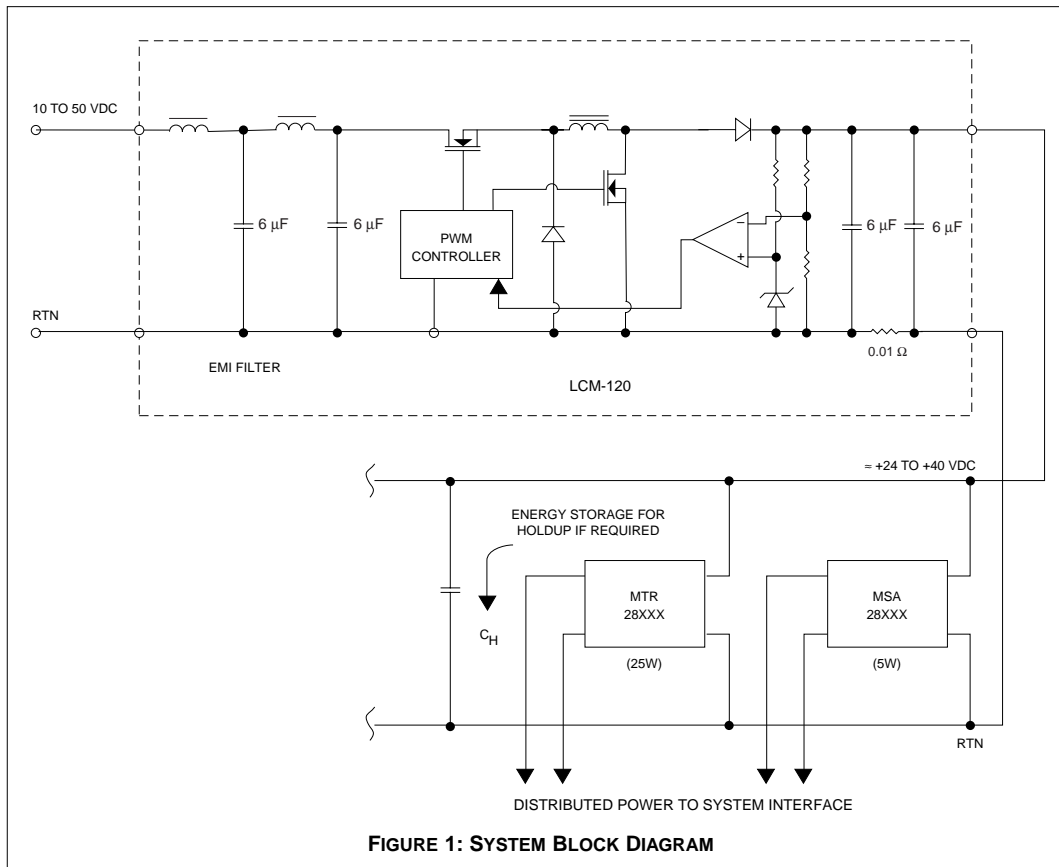

**LCM-120
120 WATT**

LINE CONDITIONING MODULE

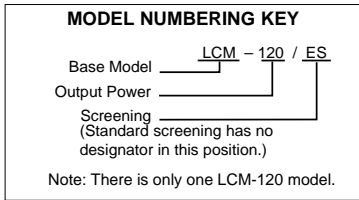
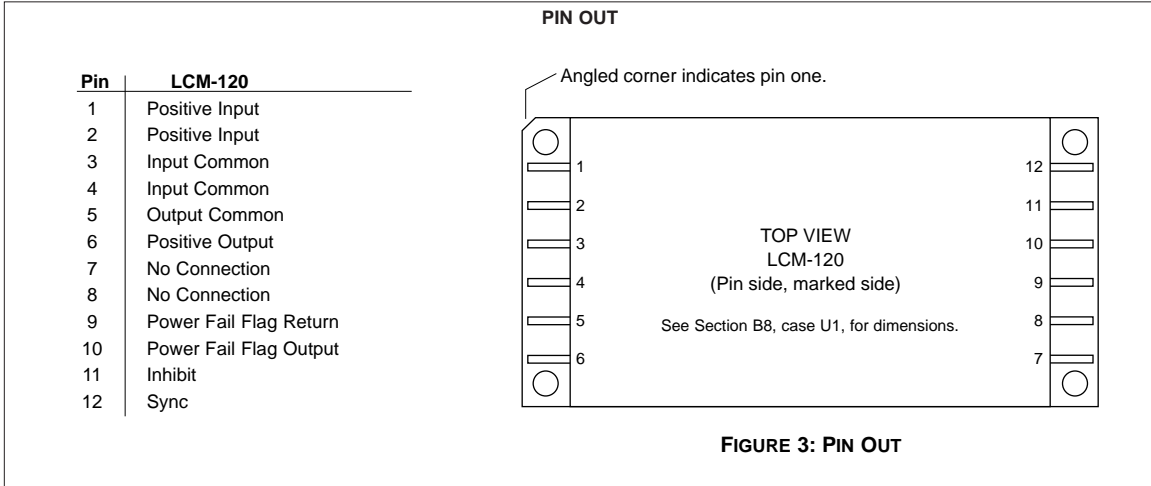

CASE U

CASES

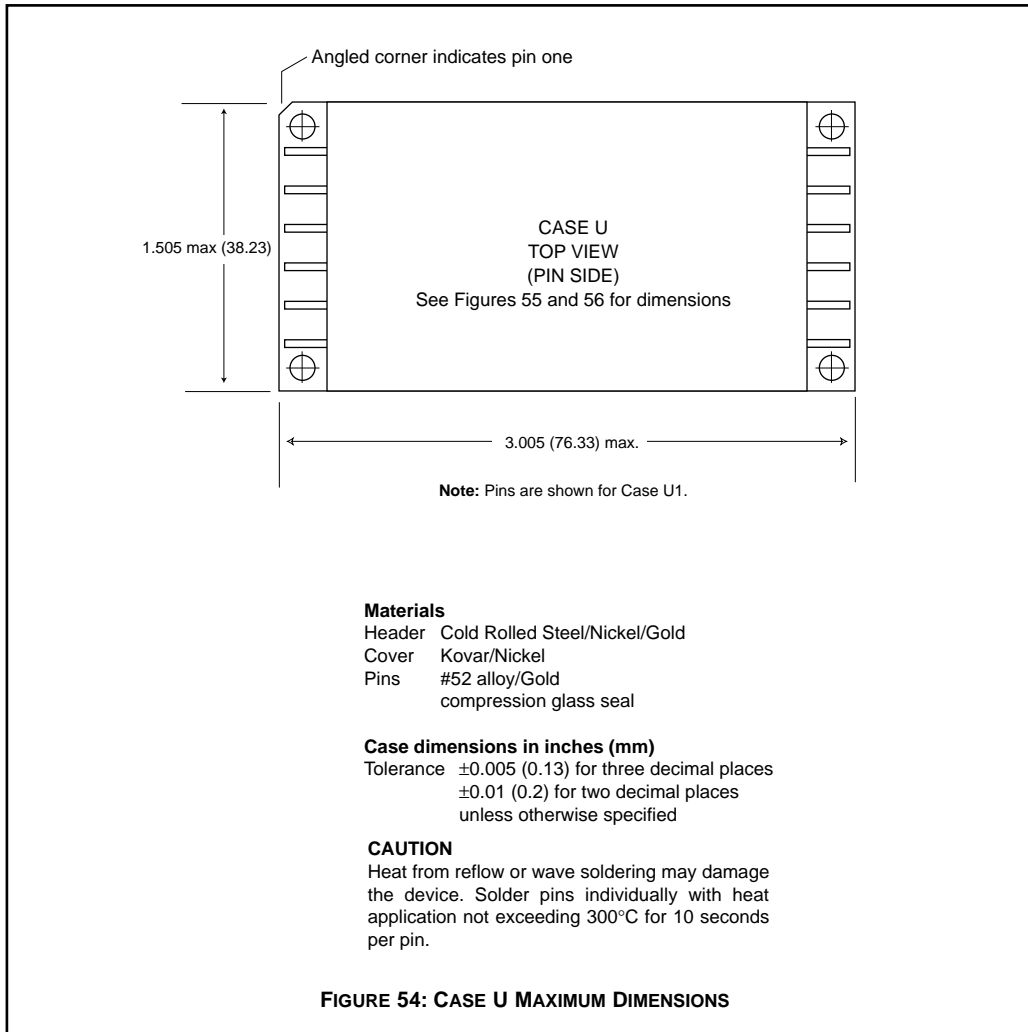

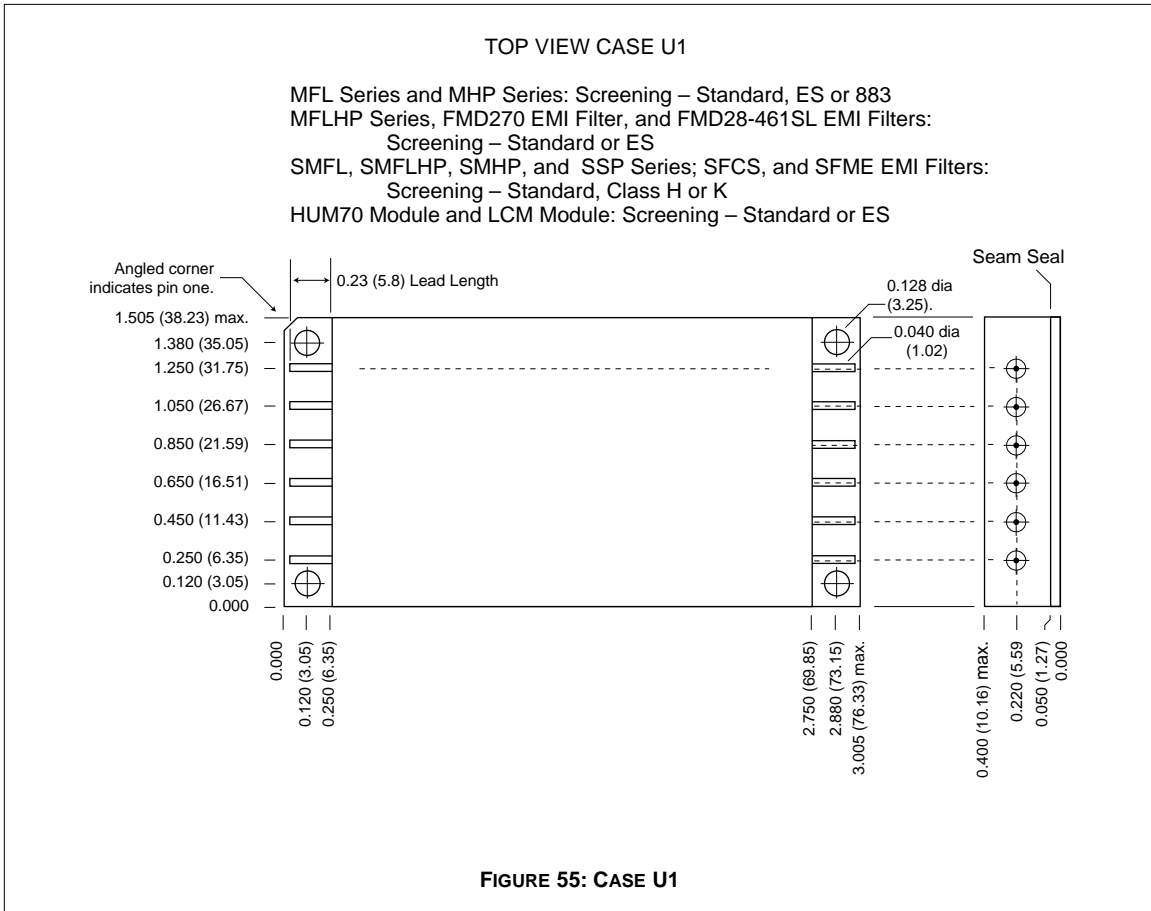

**QA SCREENING
125°C PRODUCTS**

125°C PRODUCTS

TEST (125°C Products)	STANDARD	/ES	/883 (Class H)*
PRE-CAP INSPECTION Method 2017, 2032	yes	yes	yes
TEMPERATURE CYCLE (10 times) Method 1010, Cond. C, -65°C to 150°C Method 1010, Cond. B, -55°C to 125°C	no no	no yes	yes no
CONSTANT ACCELERATION Method 2001, 3000 g Method 2001, 500 g	no no	no yes	yes no
BURN-IN Method 1015, 160 hours at 125°C 96 hours at 125°C case (typical)	no no	no yes	yes no
FINAL ELECTRICAL TEST MIL-PRF-38534, Group A Subgroups 1 through 6: -55°C, +25°C, +125°C Subgroups 1 and 4: +25°C case	no yes	no yes	yes no
HERMETICITY TESTING Fine Leak, Method 1014, Cond. A Gross Leak, Method 1014, Cond. C Gross Leak, Dip (1 x 10 ⁻³)	no no yes	yes yes no	yes yes no
FINAL VISUAL INSPECTION Method 2009	yes	yes	yes

Test methods are referenced to MIL-STD-883 as determined by MIL-PRF-38534.

*883 products are built with element evaluated components and are 100% tested and guaranteed over the full military temperature range of -55°C to +125°C.

Applies to the following products (some models do not offer “883” screening, please refer to the individual series datasheets to determine what screening is available):

MOR Series	MHD Series	MGH Series	FMGA EMI Filter
MFLHP Series	MHV Series	MCH Series	FMSA EMI Filter
MFL Series	MHF+ Series	FM-704A EMI Filter	HUM Modules
MHP Series	MHF Series	FMD/FME EMI Filter	LCM Modules
MTR Series	MGA Series	FMC EMI Filter	LIM Modules
MQO Series	MSA Series	FMH EMI Filter	